

## Specifications

### ■LGS

Item	Specification	Remarks
Velocity definition	SpX : Velocity of tire running direction SpY : Velocity of lateral direction	
Angles	SA : Slip Angle – Angle of velocity of tire running direction and lateral direction CA : Camber Angle – Roll angle around X axis PA : Pitch Angle – Pitch angle around Y axis	
Tire dynamic radius	Tr : Distance between tire center and ground	
Running distance	DdX : Distance of tire running direction DdY : Distance of lateral direction	Integrated speed
Resolution of velocity	±0.2 % or 0.006 km/h	
Resolution of ground distance	50μm	
Resolution of angles	SA : 0.002 [rad] ≒ 0.115 [deg] CA : 3.57E-4 [rad] ≒ 0.0205 [deg] PA : 2.08E-4 [rad] ≒ 0.0119 [deg]	Distance between displacement sensors X: 240 mm Y: 140 mm
Speed detection range	±144 km/h or, from -4 km/h to 318 km/h	
Detection range of ground distance	±50 mm around focus point	
Attachment	Metal fitting	
Weight	3.3 kg	Including fitting
Waterproofing	IP65	
Measurement and controller		
Sampling speed	1 kHz	
Data interpolation	Selectable from ON and OFF	
Data output device	RS-485	
Data output frequency	500 Hz	
Dimensions	*	*
Power supply	*	*
Operation temperature range	*	*
Operation humidity range	*	*
Weight	*	*

\*Please refer to WFS specification list.

### ■VMS

Unit		
Sampling speed	1 kHz	
Control cycle	200 Hz	
Shared data	CAN ID 10	
Data logging	CAN communication throughput data save	
Saved items	Time index (sec), Time index (μsec), Port number, CAN-ID, CAN data (from 0 to 64bit)	
Data save format	Binary	CSV conversion by original data viewer
Maximum save speed	8 Mbps	
Method of save command	GUI from touch screen or PC	
CAN input	8 ch maximum 1 Mbps/ch	
Digital input		
Dimensions	*	*
Power supply	*	*
Operation temperature range	*	*
Operation humidity range	*	*
Weight	*	*

\*Please refer to WFS specification list



**Safety Warning!**

●For proper use, read the instruction manuals carefully before use.

# VMS

## Vehicle Measurement System



**AND** ...Clearly a Better Value

**A&D Company, Limited**  
3-23-14 Higashi Ikebukuro Toshima Ku, Tokyo 170-0013 JAPAN  
Telephone:[81](3) 5391-6132 Fax:[81](3) 5391-6148  
http://www.aandd.jp

**A&D Technology, Inc.**  
4622 Runway Blvd. Ann Arbor, MI 48108 U.S.A.  
Telephone:[1](734) 973-1111 Fax:[1](734) 973-1103  
http://www.aanddtech.com

**A&D Europe GmbH**  
Im Leuschnerpark 4, D-64347 Griesheim,  
GERMANY  
Telephone:[49](6155) 605 250 Fax:[49](6155) 605 100

**A&D Technology Trading (Shanghai) Co., Ltd.**  
21A, Majesty Building, No.138 Pudong Avenue,  
Pudong New Area, Shanghai, 200120, CHINA  
Telephone:[86](21) 3393-2340 Fax:[86](21) 3393-2347

**A&D Europe GmbH UK Branch**  
Unit 24/26 Blacklands Way Abingdon Business Park,  
Abingdon, Oxon OX14 1DY UNITED KINGDOM  
Telephone:[44](1235) 550420 Fax:[44](1235) 550485

**A&D Australasia Pty Ltd.**  
32, Dew Street, Thebarton, South Australia 5031 AUSTRALIA  
Telephone:[61](8) 8301-8100 Fax:[61](8) 8352-7409

**A&D KOREA Limited**  
817, Manhattan Bldg., 33, Gukjegeumyung-ro 6-gil,  
Yeongdeungpo-gu, Seoul, 150-749, KOREA  
Telephone:[82](2) 780-4101 Fax:[82](2) 782-4280

●Appearances and/or specifications subject to improvement without notice.  
●Contents of this catalog last updated October 2014.

\*VMS datasheet-ADCC-01-BP1-14b01

**AND** ...Clearly a Better Value  
**A&D Company, Limited**  
http://www.aandd.jp

## Introduction

Understanding vehicles' behaviors under real driving conditions is essential in order to optimize the chassis and powertrain design. Particularly, recent vehicles' demand for improved fuel economy and driving comfort requires optimizing the total balance of vehicles.

Mounting various sensors to the vehicle and measuring the force, posture, position of the vehicle, and velocities relative to the ground is the best approach for measuring a vehicle's behavior.

There are demands for measuring how the vehicle is transferring the power generated from the engine/motor to real road surfaces in various driving conditions for improving fuel efficiency. In order to understand energy loss from driving maneuvers, a total measurement solution for the vehicle is required.

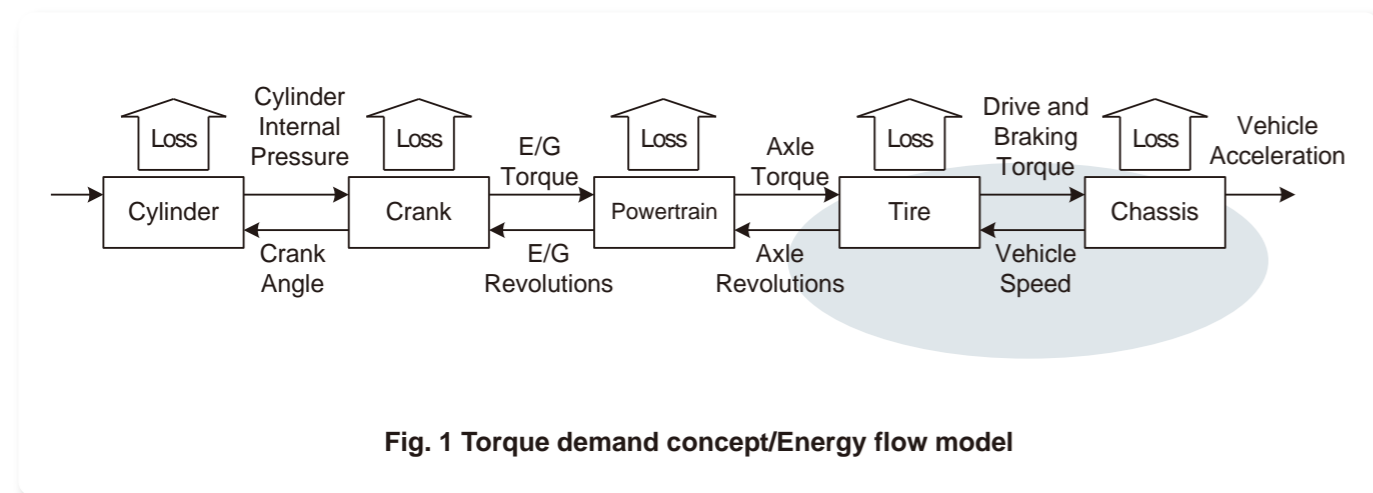

Fig. 1 Torque demand concept/Energy flow model

The figure above shows an energy flow model of the powertrain system of a vehicle.

The energy generated by the power source is transferred to the tire and then to the road to accelerate the vehicle. The most unknown component of this energy flow is the energy transfer from the tire to the road. Recent study shows wheel alignment, such as tow-in angle and camber angle, has significant influence on energy losses. Moreover, pitch angle and rolling of the chassis also have an influence on energy transfer characteristics.

Understanding energy transfer of the vehicle requires precise measurement of forces and the position of the wheel and the driving direction of vehicles.

A&D offers a total measurement solution for measuring vehicle dynamics with Vehicle Measurement System (VMS).



## Consolidated vehicle measuring concept: VMS-8

### Consolidated Vehicle Measuring Concept

Measurement requirements for vehicle dynamics are various. Not only for force, position and velocity measurement, but also various sensor and ECU data needs to be measured and logged with a synchronized time frame. Time alignments on all measurement sensors are essential in order to understand and analyze vehicle dynamics.

A consolidated vehicle measuring concept offers a collective management system for all the sensors installed on the vehicle, regardless of sensor manufacturers, and provides a seamless testing and post-processing environment.

Combining all sensors together, major vehicle parameters can be measured.

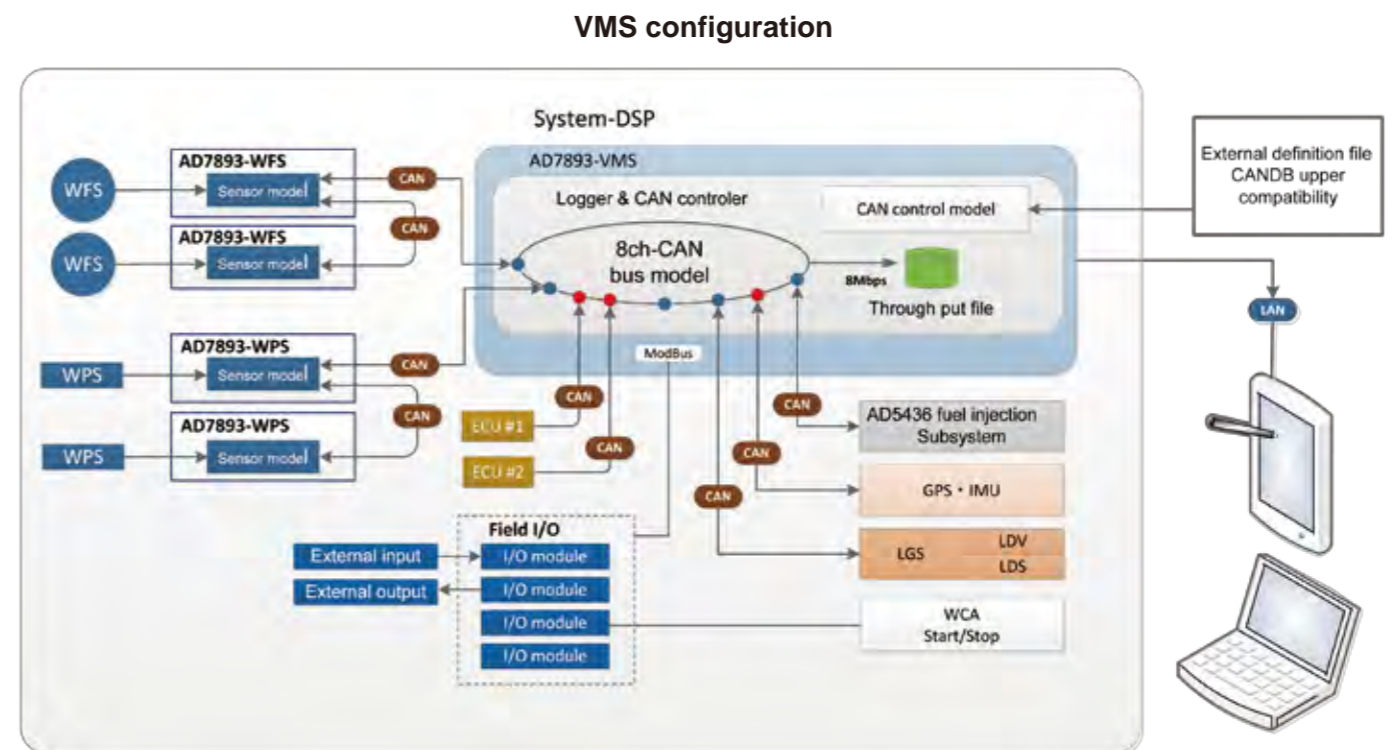

VMS-8 consists of a virtual CAN bus with eight CAN-BUS boards, simulating an eight CAN-BUS module running with one CAN-BUS line, but with 8 times more throughput. Not only is time synchronized for all CAN-BUS lines, but also command signals such as propagation and request messages are communicated along the 8 CAN-BUS lines.

With this feature, users can configure a measurement strategy to their own preferences.

CAN-BUS setting can be done simply at the touch panel screen of the VMS-8 and all connections are treated the same. For acquiring ECU data, VMS-8 can work in ListenOnlyMode so that it does not interfere with any ECU communication. Data logged via CAN-BUS lines is stored in a  $\mu$ SD card as a binary file.

■ System Configuration of VMS-8

VMS-8 is a measurement control and data logging system equipped with eight CAN-BUS lines with time synchronization to each other. VMS-8 provides complete measurement of the dynamic performance of a vehicle without using a PC.

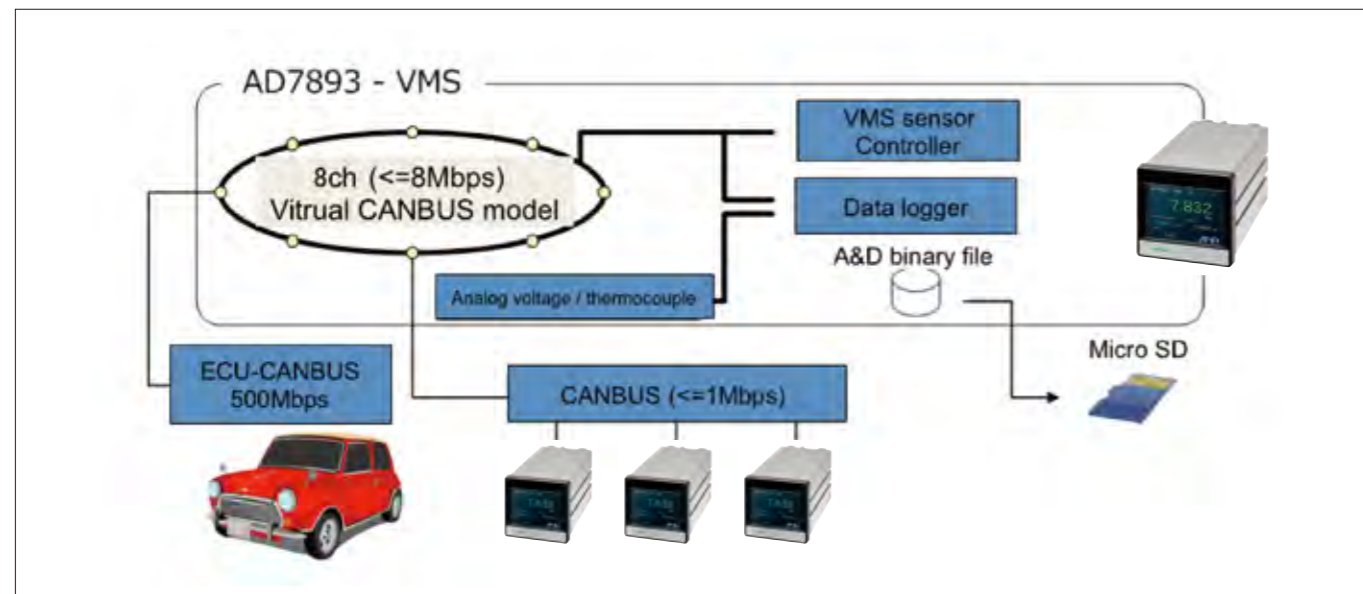

■ Data collection for A&D standard measurement instruments

Data acquisition for standard sensors is controlled from VMS-8. VMS-8 sends "SYNC" messages with request ID to all buses to which A&D's standard devices are connected. The standard devices then reply to the request with sensor data and Request ID. VMS-8 receives data according to Request ID priority. Therefore, total response time will be limited to the numbers of devices connected to the Bus system.

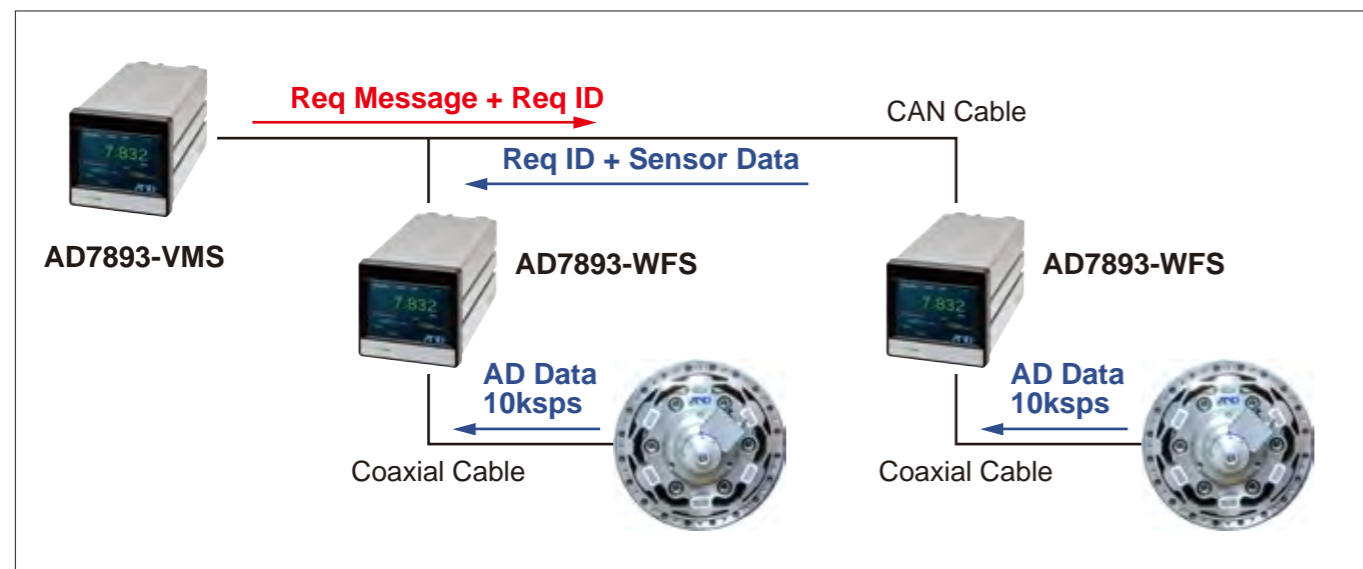

■ Data collection for non-A&D measurement instruments

There are various measurement instruments which need to be connected to the time-synchronized bus system. Measurement instruments equipped with a CAN-BUS interface can be directly connected to the VMS-8 Virtual CAN-BUS.

Sensors with output format other than CAN can be connected via the AD7893 interface unit. AD7893 is a signal CAN converter equipped with various interfaces such as Serial communication and Ethernet communication.

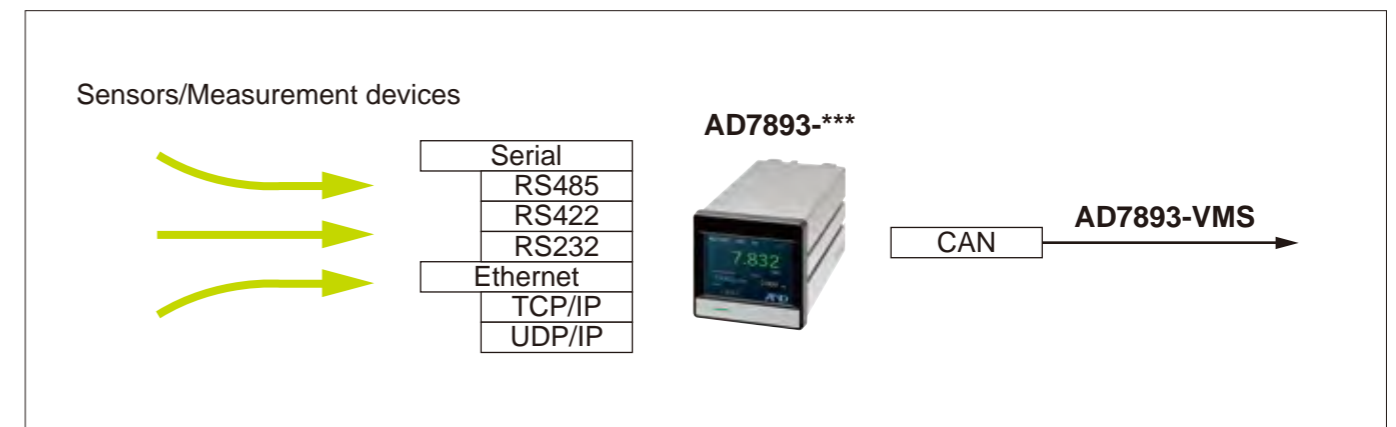
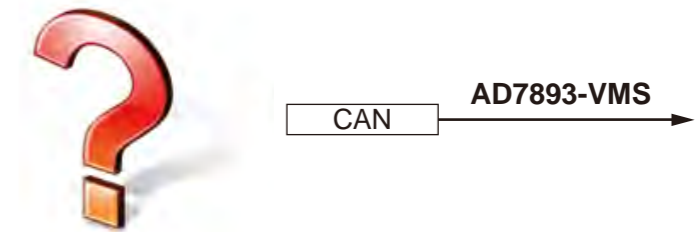

■ On-board cabling and Rack mounting

VMS-8 and all controllers for sensors have DIN housing and the weight of each box is 1.9kg. Both left and right sides have a DIN rail frame and the system can be enhanced in horizontal and lateral directions according to the size of the system. This feature offers flexible enhancement of the measurement system while taking up less space. Sensor setting can be done on the touch panel screen on the measurement controller and data will be stored on a μSD card which enables PC-less system configuration. An on-board remote controller is available for Start/Stop/Zero measurement control at the driver's seat.

A standard connector for CAN cables is available and the connector is branched internally with two parallel ports prepared. This feature requires no additional cable when reconfiguring the bus system. CAN bus terminals require terminal resistance, however terminal resistance is embedded in the measurement controller and can be configured by software, therefore no additional cable modification is necessary.



■ Sensor line up

**Wheel Force Sensor: WFS AD7811**

The WFS is designed to measure the 6 component forces of the wheel to as near as possible to realistic driving conditions. Sensor design is optimized for low temperature gradient effect, and has a low weight in order to be closer to a normal rim. This allows it to reproduce actual driving conditions.

**Features**

- High resolution of 1/4000
- High accuracy of  $\pm 0.1\%$
- Adaptation with various rim sizes



**Wheel Position Sensor : WPS AD7852**

The angle data is used to calculate the wheel position relative to the vehicle body.

**Features**

- High resolution 17 bit rotary encoder
- No need for calibration
- Attachable to standard rim
- IP65 waterproof



**Laser Ground Sensor: LGS AD7862**

The Laser Ground Sensor (LGS) consists of Doppler velocimeters and a laser distance sensor. Velocimeters measure the vehicle speed, while the ground sensor measures the height of the vehicle.

**Features**

- Measurable in sunny weather\*
- Measurable under snowy or wet conditions
- Attachable to standard rim



**Measurement controller and logger: VMS-8 AD7893-VMS**

Sensor controller with data logger.

**Features**

- CAN boards
- Data is saved with various indexes
- Throughput file maximum 8 Mbps bandwidth.



\* With filter (option)

**Case study: Measurement results**

**Figure-eight maneuvers at testing ground**

The driving maneuver performed was a figure-eight turn on a dry surface. Data was measured with a 200Hz sampling rate.

Measurement parameters:

- Vertical Load: WFS
- Lateral Force: WFS
- Suspension Stroke: WPS
- Slip Angle: LGS

$$Slip\ Angle = atan\left(\frac{V_y}{V_x}\right)$$

$V_x$  : Drag velocity  
 $V_y$  : Lateral velocity

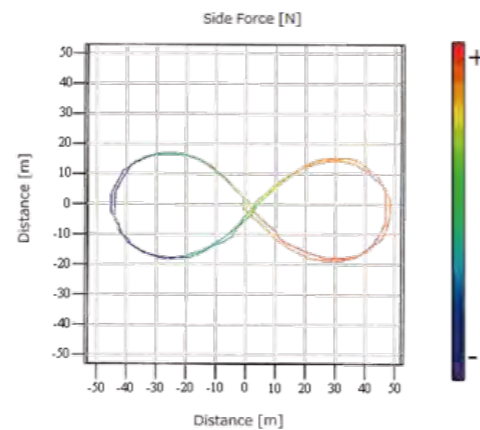

GPS data is measured as well in the graph on the right. Lateral force is shown as color.

**Data Analysis**

● Suspension Characteristics

Aligning Vertical Load and Suspension Stroke on the same time line, both parameters' movements are synchronized. The Suspension Stroke occurs due to change of Vertical Load.

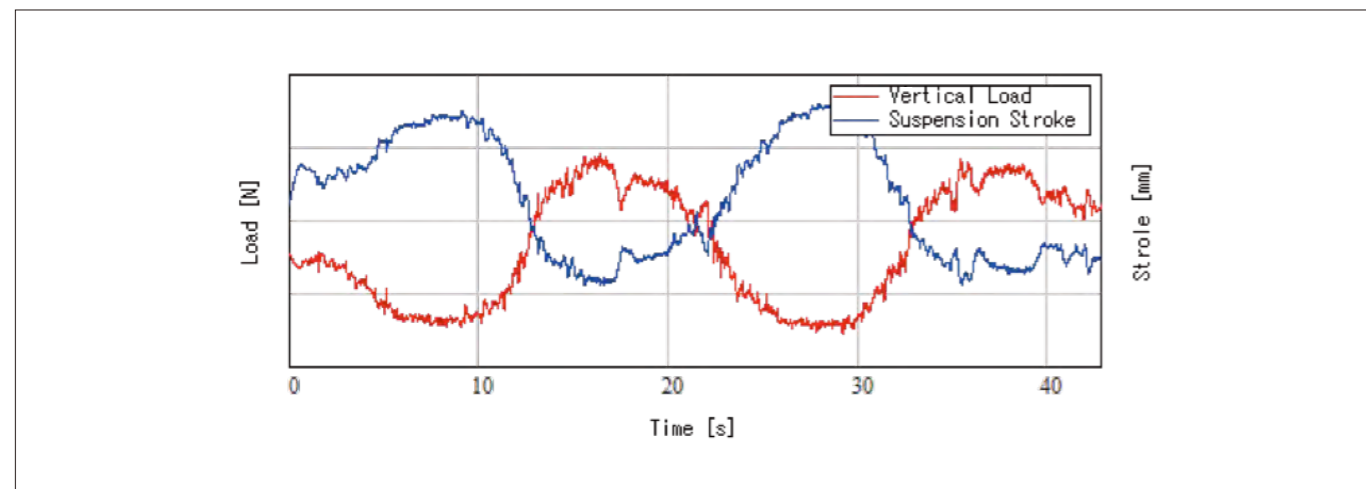

When plotting these two data sets into a 2D graph, load characteristics of suspension can be analyzed.

Only two figure-eight laps were made, however this was sufficient to observe all suspension characteristics clearly in relation to Vertical Load. Since resolutions of the sensors are high, such characteristic analysis is possible while performing real driving maneuvers with various disturbance conditions.

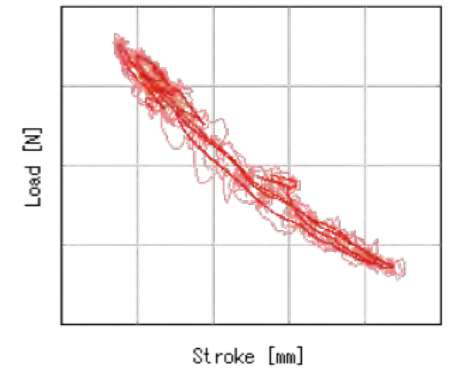

● Tire slip characteristic

In the same way, when plotting Lateral Force and Slip Angle on the same time line, it is possible to observe a synchronized change in the relation.

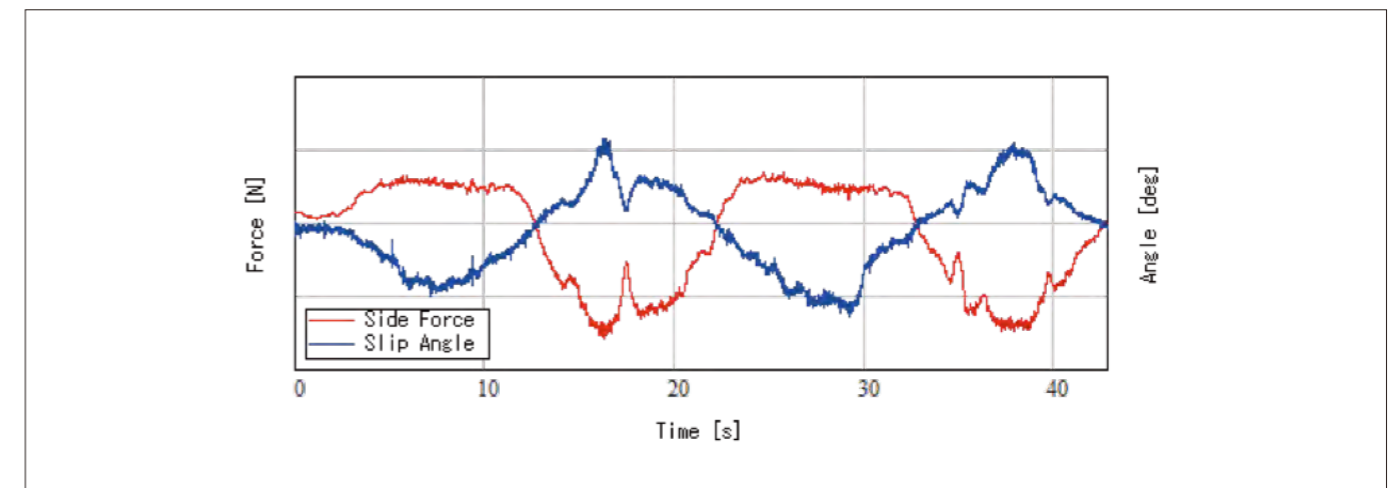

When plotting these two parameters into a 2-D graph, the characteristic curve can be analyzed.

The characteristic curve in the graph on the right displays different curves on its right and left sides and Slip Angle is 0 deg in the center. Further observation data is needed to analyze this characteristic.

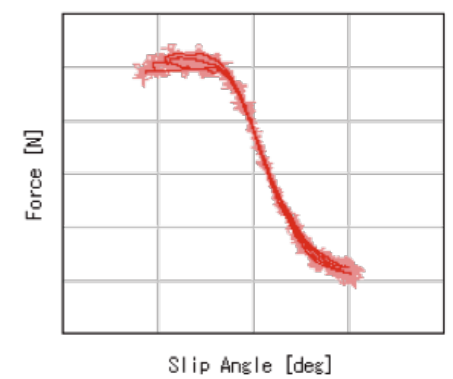

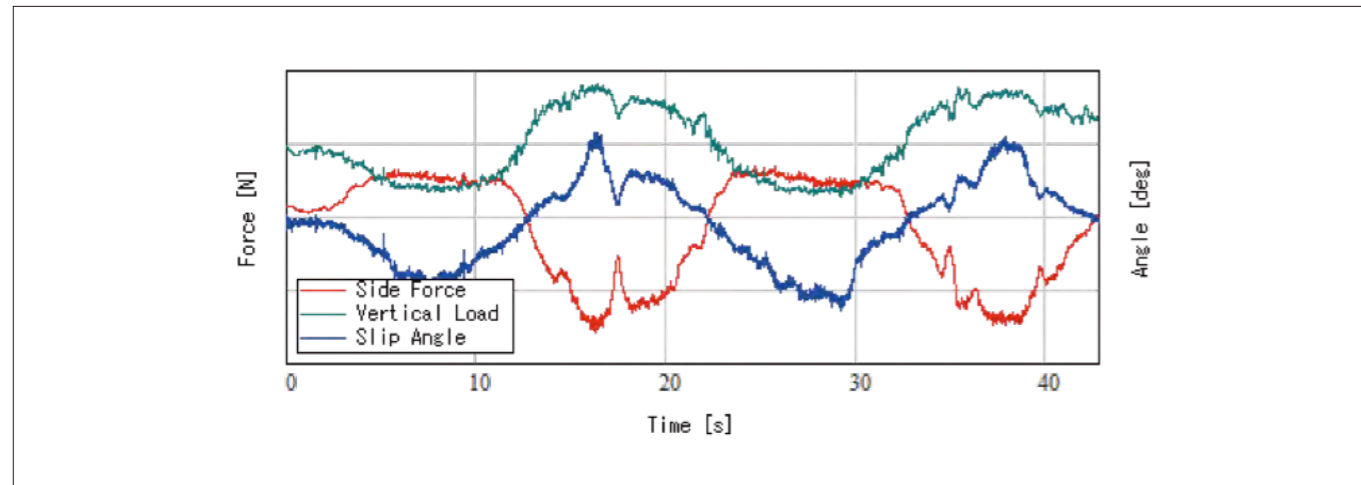

The green data above measures Vertical Load. This shows Vertical Load changes during the maneuver. It is well known that Vertical Load has a large influence on Slip Angle and Lateral Force characteristics. It can be clearly understood that Vertical Load when cornering left and right has opposite characteristics, therefore Slip Angle - Lateral Force characteristics have different curves on their left and right sides.

This case deals with Vertical Load which is quite easy to picture. However, measurement of factors other than Vertical Load are difficult to observe under road testing conditions (in this case difficult to sustain a constant Vertical Load) when various data needs to be measured on the same time line.

One more example below considers an additional Camber Angle parameter in the analysis.

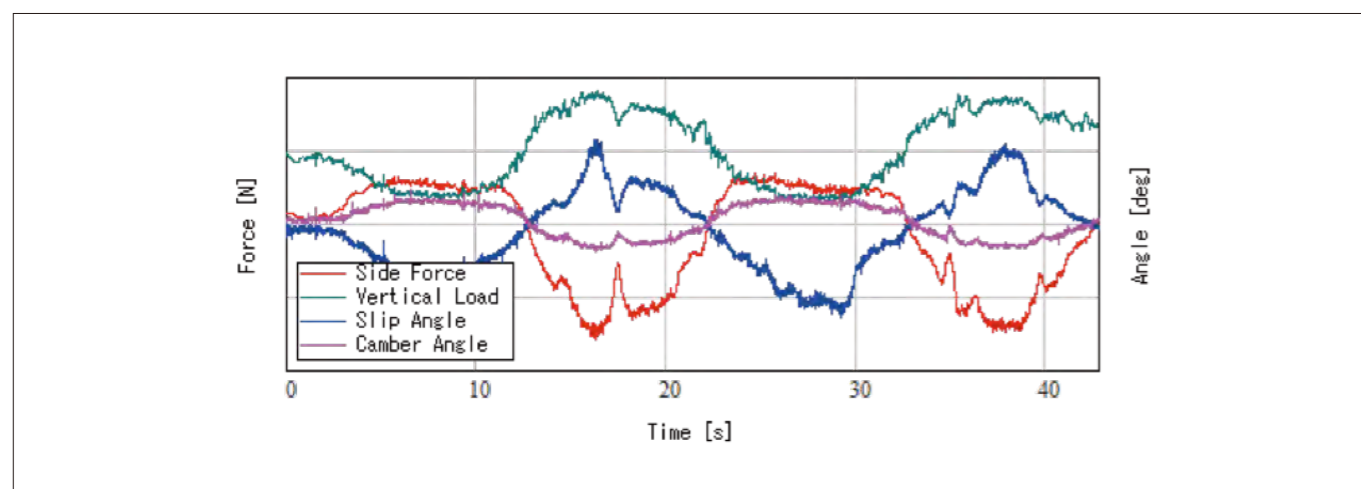
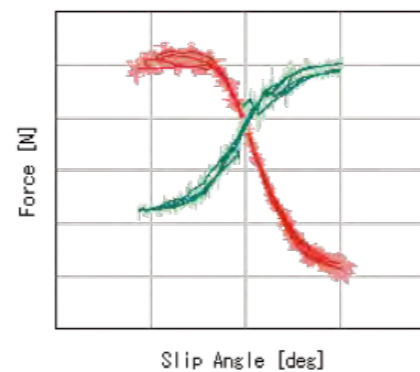

The pink curve in the graph on the right shows Slip Angle – Camber Angle characteristics. This shows Camber Angle has similar characteristics to Lateral Force, which demonstrates that Camber Angle and Lateral Force have nearly linear characteristics and Lateral Force is generated from Slip Angle and Vertical Force.

The conclusion of this case study is that in order to obtain detailed analysis at post processing stage, multiple measurement features are essential for real driving testing, as driving conditions cannot be completely reproduced on the testing bench and various environmental factors are present in the road testing environment. Extracting meaningful analysis from test data needs to measure as many parameters as possible.

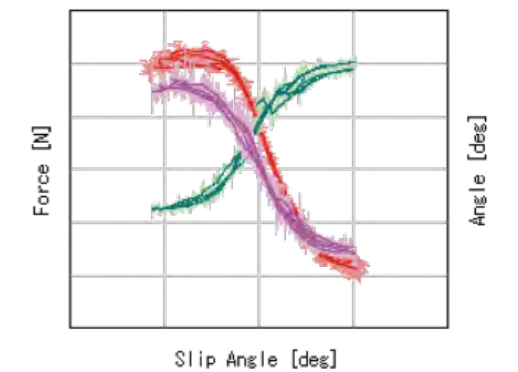

### Low $\mu$ surface test

When using laser sensors in wet conditions, splashes of water from the tires can become disturbances. This is a physical phenomenon and the laser sensor detects water splashes as string noise.

The graph below presents vehicle velocity data taken from a straight driving maneuver with patches of water in two places reproducing low  $\mu$  friction road surface. String noise is detected at the two areas with surface water. The Laser Ground Sensor has a noise cut filter function and can process filtering at three levels.

Noise-cut data is shown as a dark red color and LGS can output this data directly.

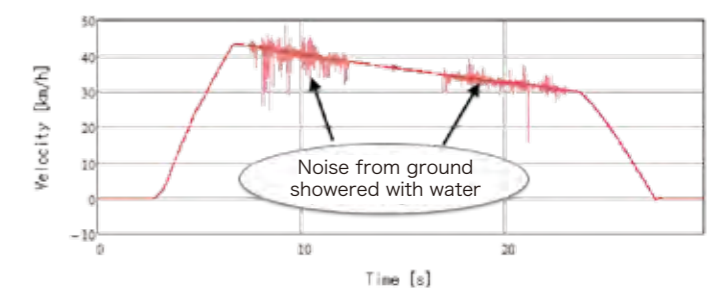

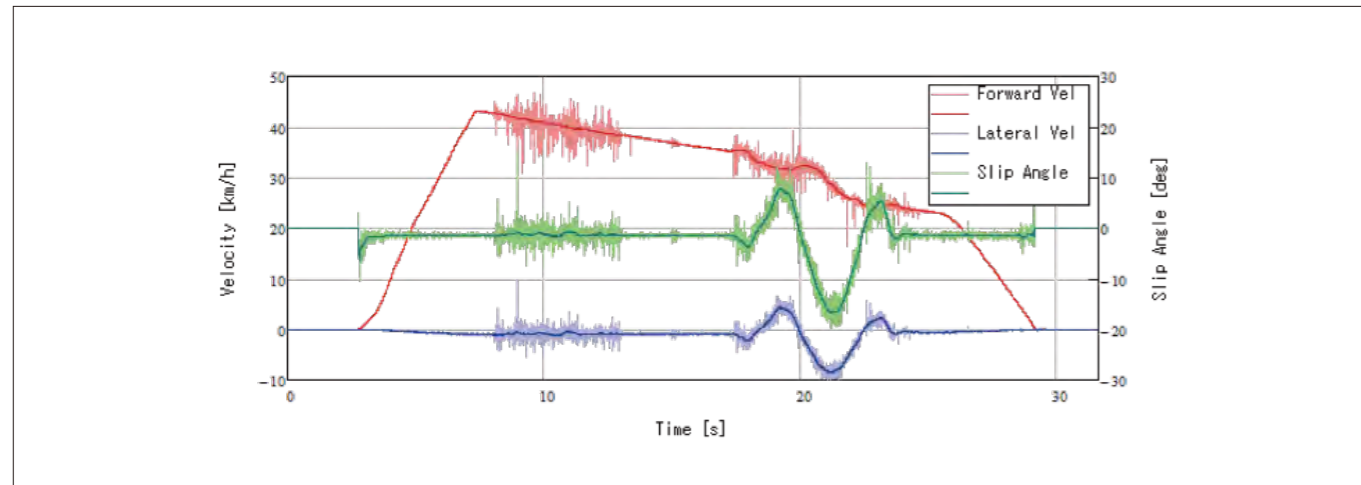

The data above is also wet condition data, but with a slight steering action at the second wet road surface area. Forward Velocity, Lateral Velocity and Slip Angle are measured with LGS. Light color data is raw data measured from the LGS and dark color data is filtered data. Filtering data narrows the measurement frequency bandwidth but LGS is detecting data with 500Hz. Therefore, even after the filtering, the data is valid for analyzing vehicle behavior.

### ■ Testing in snowy conditions

In snowy conditions using laser sensors, the tires kick up small balls of snow which create noise in the laser signal. However, measurement performance to a similar standard to rainy conditions can be achieved with filtering.

This test is focused on tire slip in the longitudinal direction. LGS measures vehicle speed against the ground and WFS measures tire rotation speed and converts it to vehicle speed. Combining these measurement parameters, Slip Ratio can be measured. The graph on the right shows acceleration conditions. Vehicle Velocity in the red curve has constant acceleration, but Tire Velocity is changing rapidly. From these two parameters, Slip Ratio can be measured with the following formula and shown as the green curve.

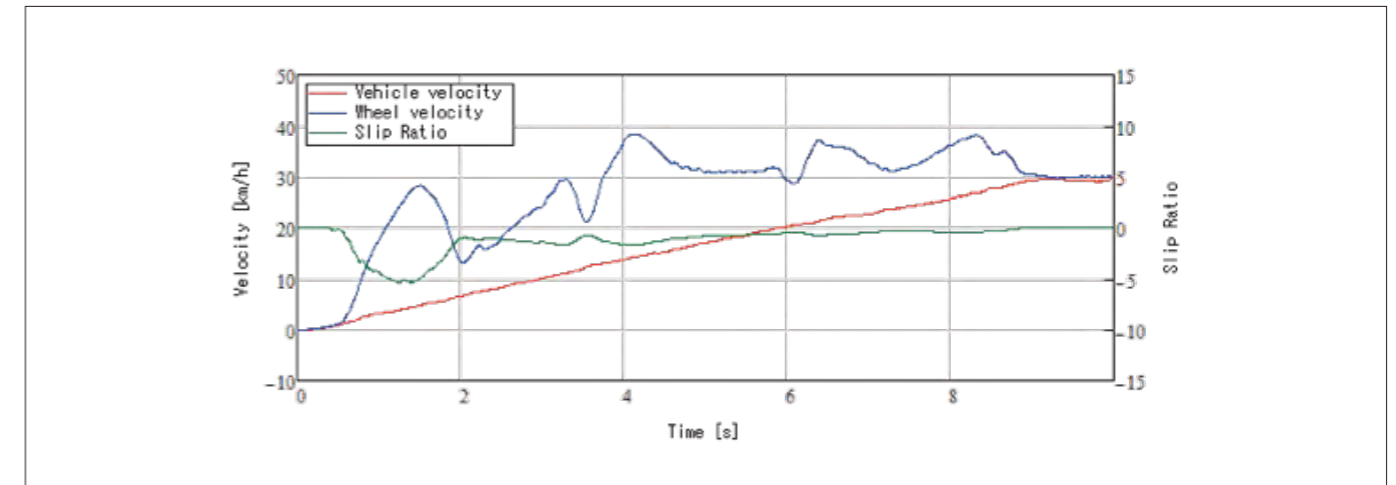
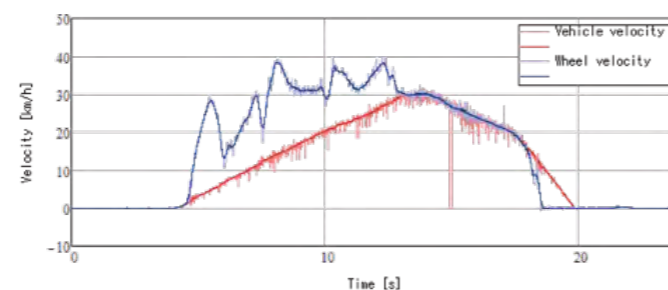

$$Slip Ratio = \frac{V_V - V_W}{V_V} \quad \begin{matrix} V_V : \text{Vehicle Velocity} \\ V_W : \text{Wheel Velocity} \end{matrix}$$

Slip Ratio can be observed dynamically from the start through acceleration.

The graph below shows deceleration conditions.

With rough braking, the tire will be locked and wheel velocity drops down to zero but the vehicle is still moving. Therefore, the red curve is detecting speed. Even with snowy conditions with filtered data, vehicle behavior can be analyzed at a dynamic level. Also, as the WFS is using a 1600 teeth encoder and LGS-utilized Doppler type velocity detection, the velocity of a vehicle can be measured at a low speed (from zero).

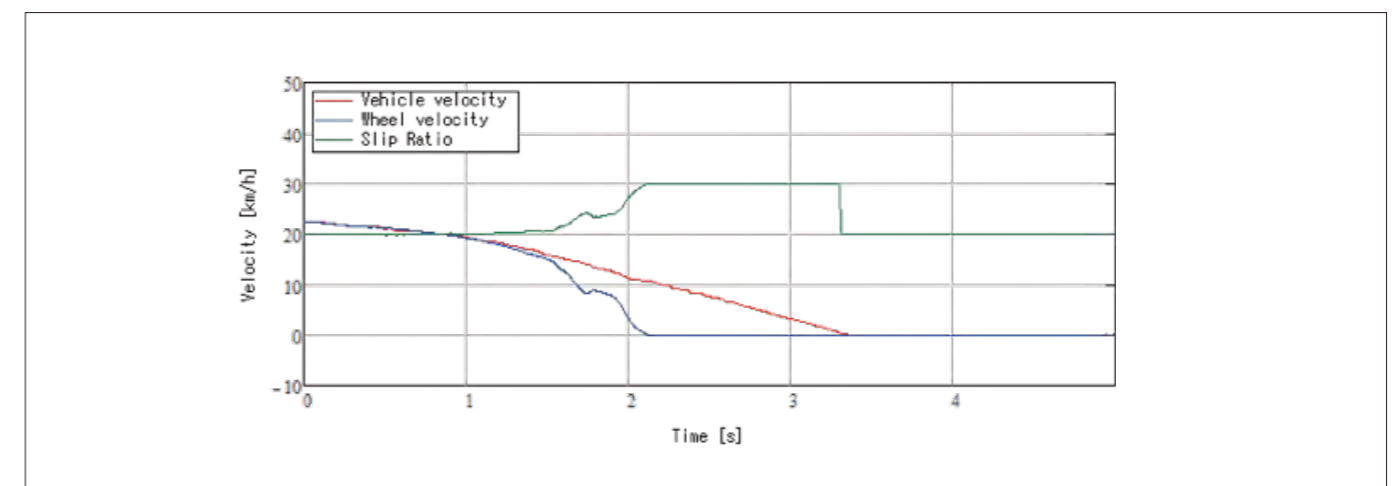

■ Braking test in dry conditions

Data in the graph below is taken on a dry road surface for measuring the braking behavior of the test vehicle. Anti-Lock Braking behavior is clearly observed.

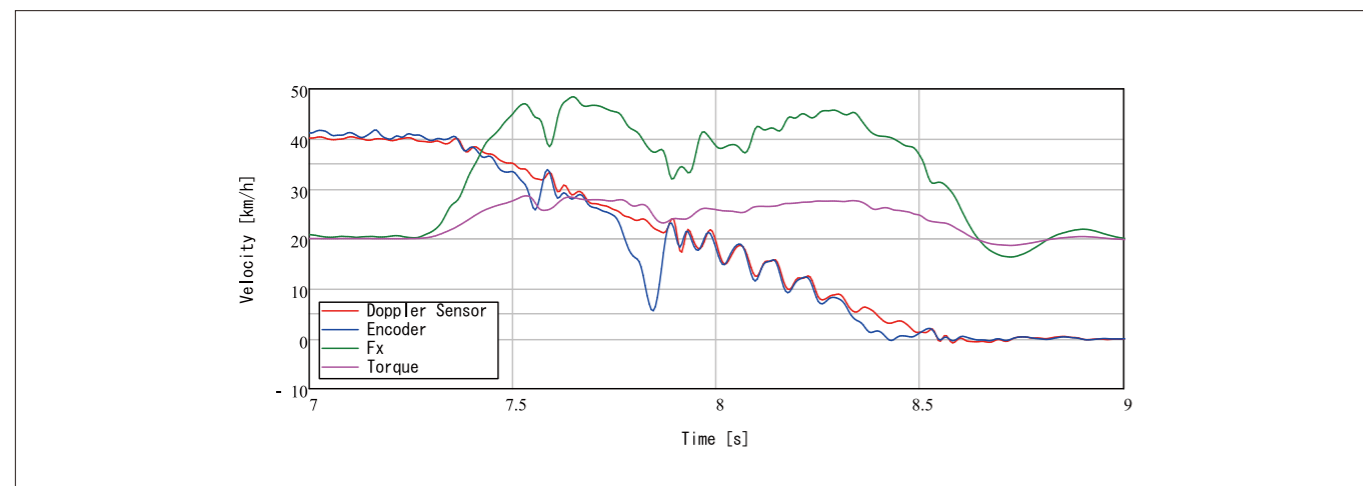

The graph above shows vehicle speed (measured by LGS), tire speed (measured by WPS), braking torque My (measured by WFS) and braking force Fx (measured by WFS) during a full braking maneuver. In the graph, repetitive behavior of the ABS system applying and releasing the brakes can be clearly observed as well as the braking performance for braking torque and force profiles. The graph shows us that the ABS system is trying to control braking torque at a constant level and it gives us useful time based quantitative analysis data for evaluating ABS performance.

Specifications

■ WFS

Item	Specification	Remarks
Method	Distributed power sensing method	
Coordinate direction is defined as :	Drive and braking direction X Vehicle axle direction Y Gravity direction Z	
WFS-24kN	Force range Moment range	Fx=24 kN, Fy=16 kN, Fz=24 kN Mx= 6 kNm, My=4.5 kNm, Mz=6 kNm
WFS-36kN	Force range Moment range	Fx=36 kN, Fy=24 kN, Fz=36 kN Mx= 9 kNm, My=6.75 kNm, Mz=9 kNm
WFS-48kN	Force range Moment range	Fx=48 kN, Fy=32 kN, Fz=48 kN Mx=12 kNm, My=9 kNm, Mz=12 kNm
Total error	±0.1 % of calibrated load range	Including linearity and hysteresis error. Calibration is performed up to 24 kN in the X and Z directions.
Modulation error	±0.5 % of calibrated load range	
Resolution	1/4000	
Angular resolution	1024/360 deg	
Temperature compensation range	-20~+80 °C	
Operation temperature range	-40~+100 °C	
Zero drift by temperature	0.005 %/°C	At maximum load
Sensitivity effect by temperature	0.005 %/°C	
Weight	3.82 kg	Reference
Waterproofing	IP65	
Measurement & controller box		
Sampling rate	1 kHz	
Low pass filter	4th order Butterworth	
	Cutoff frequency is selectable from	
	1/2/5/10/20/50/100/200/500 Hz / none	
Data output device	CAN, analog	
Data output frequency	Selectable from 1/2/5/10/20/50/100/200/500/1 kHz	
Dimensions of box	W97 mm × H97 mm × D208 mm W110 mm × H115 mm × D310 mm	Including stacking frame
Power	AC100 V	DC12 V +-10%
Operation temperature range	5~40 °C	
Operation humidity range	5~90 %RH	No condensation
Weight	1.2 kg or 2 kg including stacking frame	

■ WPS

Unit	Specification	
Direction	X:Driving direction Y:Axle direction Z:Gravity direction	
Angle definition	θx: Angle around X axis θy: Angle around Y axis θz: Angle around Z axis	θy is equal to wheel rotation angle.
Detection range	Minimum movable range* X : ±150 mm θx: ±30 deg Y : ±100 mm θy: Unlimited Z : ±180 mm θz: ±180 deg	*Converted to wheel center movement. The physical interference of an installation may reduce range.
Resolution	Encoder: 17 bit/rotation X: 0.024 mm θx: 0.0027 deg Y: 0.024 mm θy: N/A Z: 0.01 mm θz: 0.0027 deg	
Rotation detection range	0 to 360 deg	
Rotation detection resolution	0.09 deg -Tire rotation angle: 1024 P/Rx4	
Maximum tire rotation speed	3000 rpm	
Attachments	Suction cup, magnet and safety belt	
Weight	Unsprung weight 1.6 kg	
Waterproofing	IP65	

\*Please refer WFS for measurement & controller configuration.