

AD-4408A

**Weighing Indicator
for DeviceNet Interface**

AX-ABCC-DEVICE





INSTRUCTION MANUAL



1WMPD4002026

WARNING DEFINITIONS

The warnings described in this manual have the following meanings:

 WARNING	A potentially hazardous situation which, if not avoided, could result in death or serious injury.
 CAUTION	A potentially hazardous situation which, if not avoided, may result in minor or moderate injury or damage to the instrument.
	This symbol indicates caution against electrical shock. Do not touch the part where the symbol is placed.
	This symbol indicates the ground terminal.
	This symbol indicates that an operation is prohibited.
NOTE	Information or cautions to use the device correctly.

© 2009 A&D Company, Limited. All rights reserved.

No part of this publication may be reproduced, transmitted, transcribed, or translated into any language in any form by any means without the written permission of A&D Company, Limited.

The contents of this manual and the specifications of the instrument covered by this manual are subject to change for improvement without notice.

DeviceNet is a registered trademark of Open DeviceNet Vendor Association, Inc.

Anybus-CompactCom is a registered trademark of HMS Industrial Networks.

TORX is a registered trademark of Camcar Division of Textron, Inc.



Contents

1.	About This Manual.....	2
2.	Introduction.....	2
3.	Description of Each Part.....	3
3.1.	Status LEDs.....	3
3.2.	Communication Connector.....	4
4.	Installation.....	5
4.1.	Installing the Interface Module.....	5
4.2.	Outline of Physical Connection for DeviceNet.....	6
4.3.	Setting the Functions.....	6
5.	PLC Memory.....	8
5.1.	Address Map.....	8
5.1.1.	OUT Data (2ch), PLC → AD-4408A.....	8
5.1.2.	IN Data (6ch), AD-4408A → PLC.....	9
5.2.	Handling Bits Directly.....	11
5.2.1.	Handling Command Bits.....	11
5.2.2.	Command Bit Execution Procedure.....	11
5.3.	Operation by Commands.....	12
5.3.1.	Handling Commands.....	12
5.3.2.	Command Execution Procedure.....	12
5.4.	Commands.....	13
6.	Errors.....	14
6.1.	Error Types.....	14
7.	Timing Chart.....	15
7.1.	Write Command.....	15
8.	Check Mode.....	16
8.1.	Checking the DeviceNet Communication Status.....	16
8.1.1.	Entering the Check Mode.....	16
8.1.2.	Checking the Communication Status.....	17



1. About This Manual

- This manual is intended for those who have a sufficient knowledge about weighing instruments and DeviceNet.
- For general information regarding DeviceNet, specifications, wiring, installation and operation, refer to DeviceNet-related technical books.
- For information on DeviceNet or DeviceNet products, contact your local Open DeviceNet Vendor Association, Inc. (ODVA).
- When configuring a network, use cables and terminating resistors designed for DeviceNet products.



2. Introduction

- This option is the DeviceNet interface module (AX-ABCC-DEVICE) to be installed into products manufactured by A&D. Applicable products are listed on our website.
- The AD-4408A functions as a slave device of DeviceNet when the DeviceNet interface module is installed.
- Using this interface, a PLC can control the AD-4408A and read the indicated values from the AD-4408A.
- Two methods of controlling the AD-4408A by the PLC memory are available; handling bits directly and using commands.
- The AD-4408A, with the DeviceNet interface module installed, has passed the ODVA conformance testing Version CT22.

NOTE: The DeviceNet interface module, when installed into the AD-4408A, uses 4 bytes (OUT) and 12 bytes (IN) of the PLC memory. So, use much care when assigning areas, not to overlap with other slave devices.

Except during weighing or when weighing is possible, all of the IN data should be zero.

Memory map and check modes vary with the interface module installed. This manual describes performances when the DeviceNet interface module is installed.

When other modules are installed, refer to the relevant instruction manual. Instruction manuals for each interface module are available on our website.



3. Description of Each Part

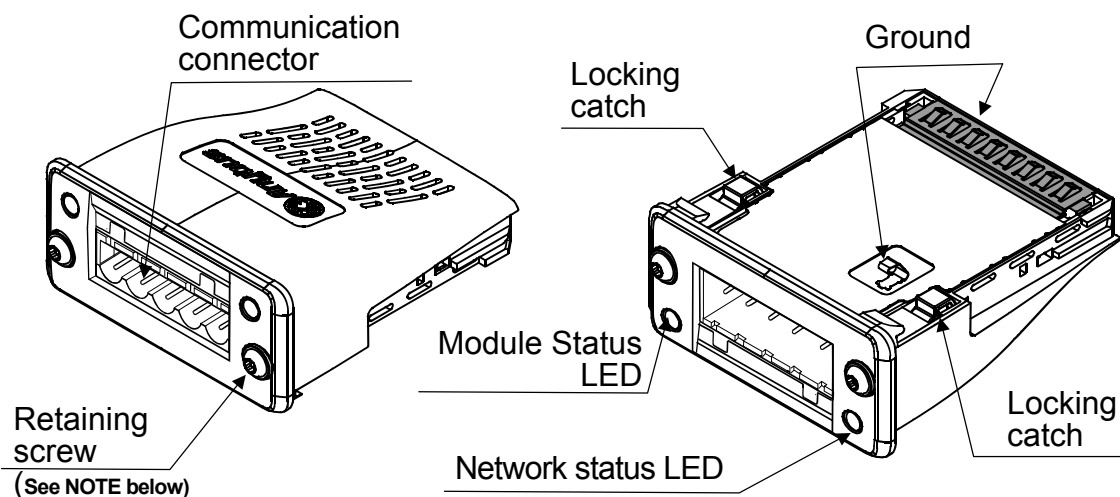

Fig.1 Interface module part names

NOTE: A TORX® driver (size T9) to fasten the retaining screws is not provided with the interface module.

3.1. Status LEDs

NOTE: The illustration below shows how the interface module is positioned when installed into the AD-4408A.

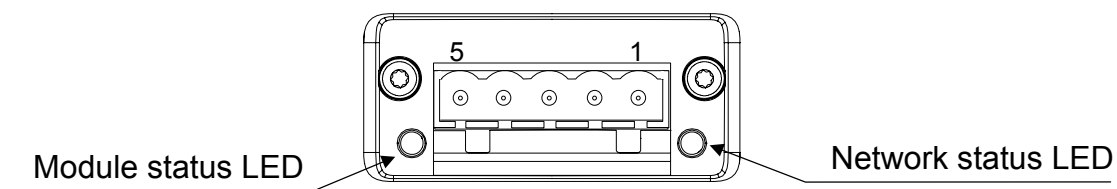

Fig.2 Position of status LEDs

Table 1 Network status LED (NS)

LED state	Description
OFF	No power / Offline
Green ON	Normal
Green, flashing	Not connected
Red ON	Duplicate node address error / Bus-off condition
Red, flashing	Connection timeout
Red/Green, flashing	Self test in progress

Table 2 Module status LED (MS)

LED state	Description
OFF	No power
Green ON	Normal
Green, flashing	Standby
Red ON	Unrecoverable fault
Red, flashing	Recoverable fault
Red/Green, flashing	Self test in progress

3.2. Communication Connector

NOTE: The illustration below shows how the interface module is positioned when installed into the AD-4408A.

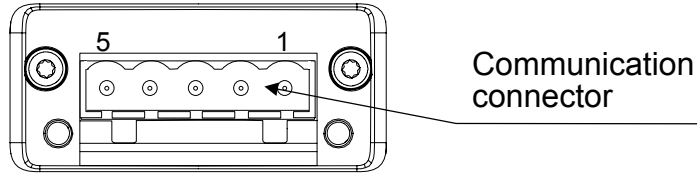

Fig.3 Connector pin assignment

Functions for each pin are as follows.

Table 3 Communication connector

Pin No.	Signal	Description
1	V-	Negative bus supply voltage
2	CAN_L	CAN low bus line
3	SHIELD	Cable shield
4	CAN_H	CAN high bus line
5	V+	Positive bus supply voltage



4. Installation

4.1. Installing the Interface Module

⚠ CAUTION

Be sure to disconnect the AD-4408A from the power source before installing the interface module.

Install the interface module as follows:

Step 1 Using a Phillips screwdriver, loosen the screws that secure the blank panel to the AD-4408A rear panel, and remove the blank panel.

Step 2 Insert the interface module into the option slot as shown to the right.

Step 3 Insert the interface module until it mates with the terminals of the PC board connector located in the option slot.

Step 4 Using a TORX[®] driver (size T9), fasten the retaining screws with a tightening torque of 0.25 Nm in the clockwise direction to secure the interface module.

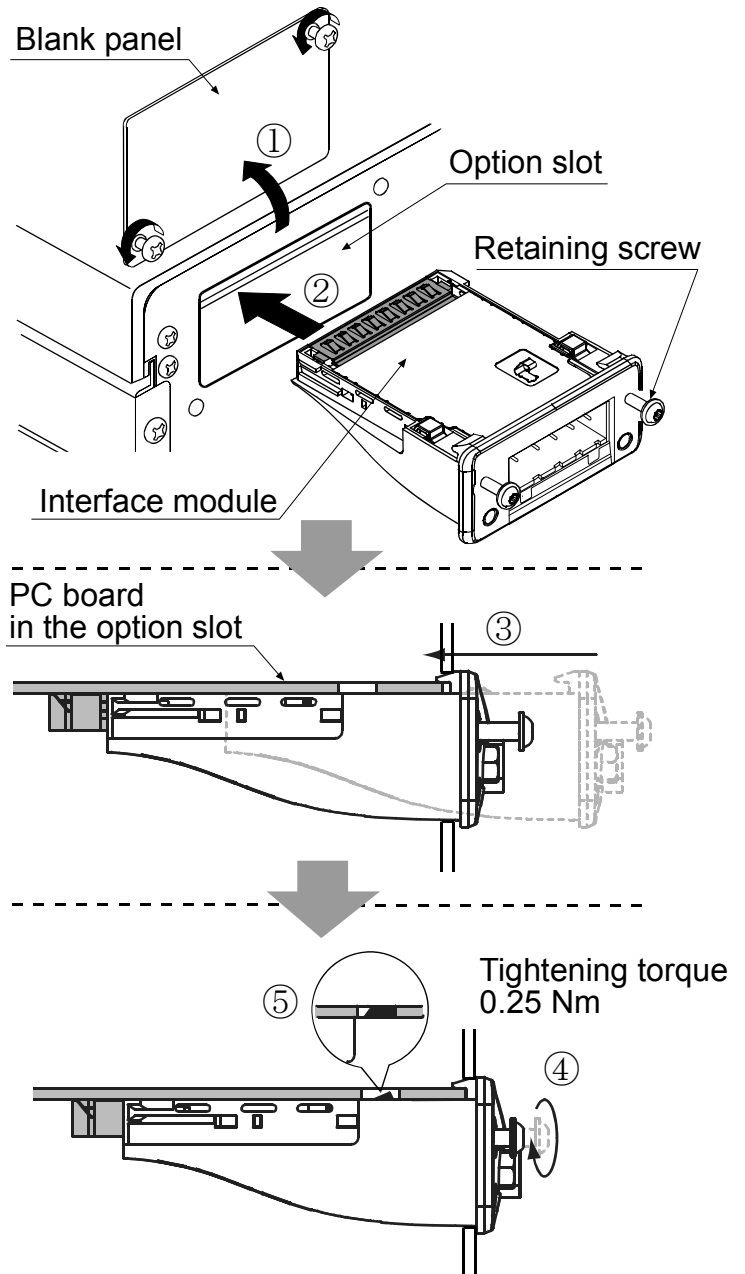

Fig.4 Interface module installation

NOTE: A TORX[®] driver is not provided with the interface module.

4.2. Outline of Physical Connection for DeviceNet

- This slave device consumes 50 mA maximum from the network.
- Install a terminating resistor at both ends of the trunk line.
- When a thin cable is used, the maximum cable distance of the trunk line is less than 100 m. When a thick cable is used, the maximum cable distance depends on the baud rate.
- The maximum length of a drop line is less than 6 m. The cumulative length of drop lines depends on the baud rate.
- Connect the cable shield to the ground terminal of the power tap, and ground them.

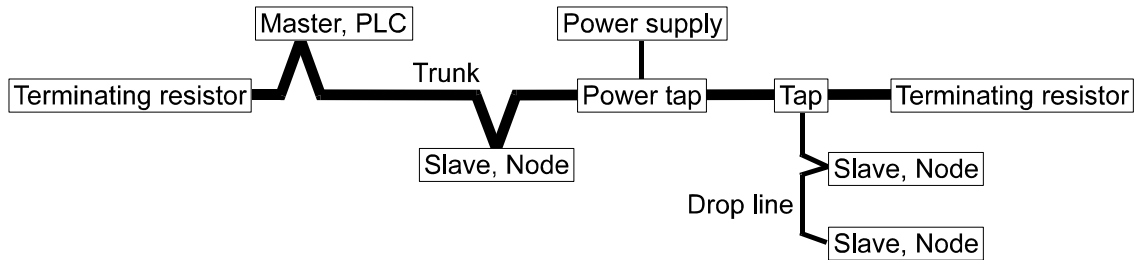

Table 4 Baud rate and cable distance

Baud Rate	Maximum Cable Distance			
	Trunk Line		Drop Line	
	Thin Cable	Thick Cable	Cumulative Length	Maximum Length
125 kbps	100 m	500 m	156 m	6 m
250 kbps		250 m	78 m	
500 kbps		100 m	39 m	

When configuring a network, use cables and terminating resistors designed for DeviceNet products.

4.3. Setting the Functions

The functions described here are general functions.

General functions are divided into groups per function and are indicated by the group name followed with the function number, FXX.

NOTE: General functions determine the AD-4408A performance and all of the settings are stored in the FRAM.

Setting Procedure

Step 1 While pressing and holding the ENTER key, press the F key.

$F_{n\text{C}}$ is displayed to indicate that the indicator will enter the general function mode.

Step 2 Press the ENTER key. The indicator enters the general function mode.
To go back to the weighing mode without entering the general function mode, press the ESC key.

Step 3 Press the \uparrow or \downarrow key to select the function group to be set.

Display	Group name
<i>dn F</i>	DeviceNet-related functions

Press the ENTER key. A function number will be displayed.

Function No.	Function	Description	Default value
<i>dn F01</i> 0 to 63	Node	<i>n</i> : Node	63
<i>dn F02</i> 0 to 3	Baud rate	0: 125 kbps 1: 250 kbps 2: 500 kbps 3: Auto	3

Step 4 Press the \uparrow or \downarrow key to select the function number to be set.
Press the ENTER key. The current setting value will be displayed.

Step 5 Change the setting value using either one of the methods below.

Method	Description
Selecting a parameter	Only the parameter number to be selected is displayed and blinks. Press the \uparrow or \downarrow key to select a parameter.
Inputting the value	All the digits are displayed and a digit to be changed blinks. Press the \leftarrow or \rightarrow key to select a digit and press the \uparrow or \downarrow key to change the value.

After setting, press the ENTER key. The next function number is displayed.
When the parameter is not to be changed, press the ESC key to return to the function number display.

Step 6 Press the ESC key. The function number disappears and the indicator returns to the state of step 3.
Press the ESC key to store the setting values in the FRAM and go back to the weighing mode.

NOTE: The blinking decimal point indicates that the current value is not the weight value.

If a value exceeding the settable range is entered, $\boxed{Err dt}$ is displayed and the input is canceled.



5. PLC Memory

5.1. Address Map

- Commands to operate the AD-4408A and operating parameters are written into the PLC memory OUT data (2ch) and are executed.
- Response data from the AD-4408A is provided for the PLC memory IN data (6ch).

NOTE: The DeviceNet interface module, when installed into the AD-4408A, uses 4 bytes (OUT) and 12 bytes (IN) of the PLC memory. So, use much care when assigning areas, not to overlap with other slave devices.

5.1.1. OUT Data (2ch), PLC → AD-4408A

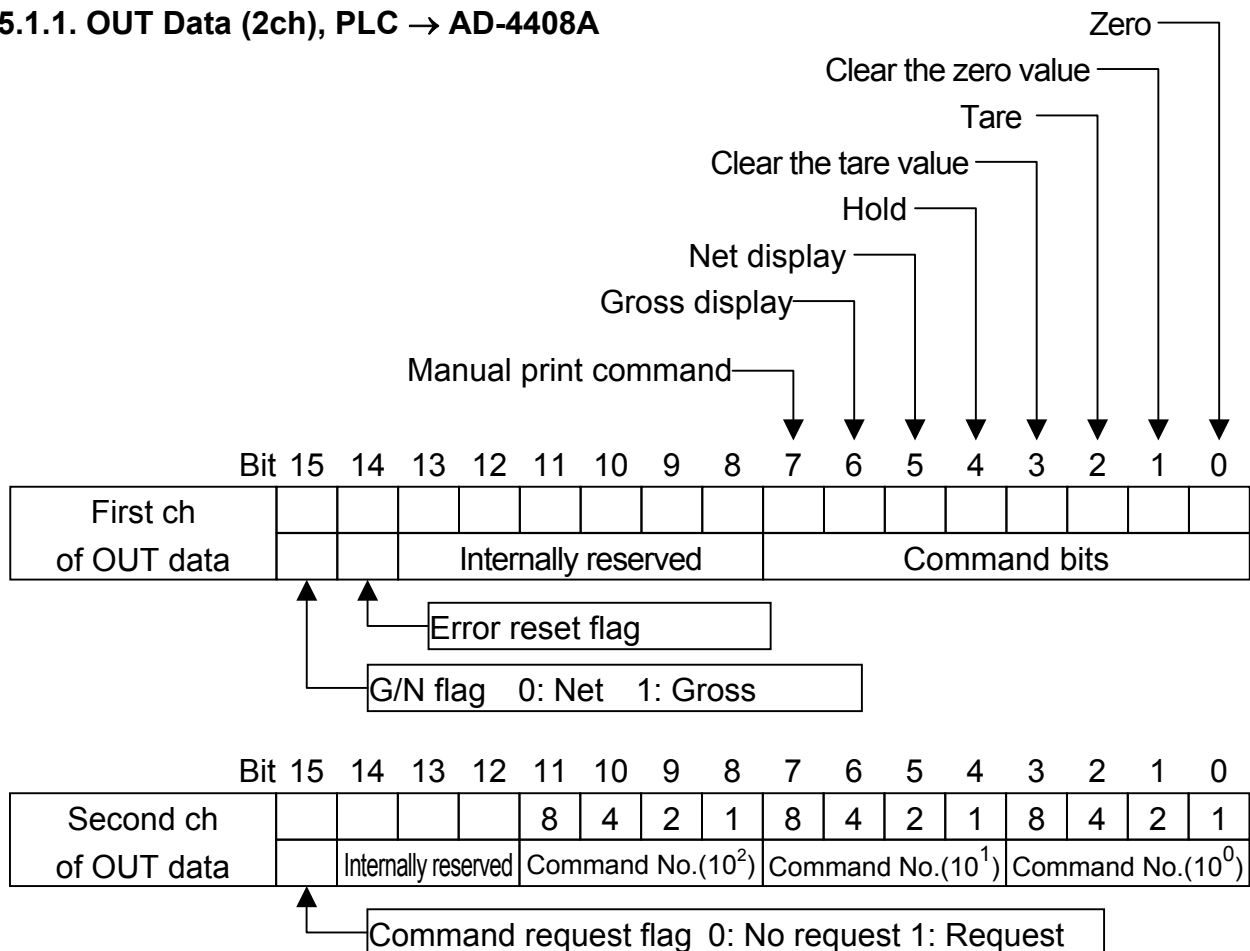

About OUT Data

Command bits-----Assigns a function to execute to each bit.

Command No.-----Specifies a command number to execute.

Internally reserved -----Do not write anything other than 0 (zero).

5.1.2. IN Data (6ch), AD-4408A → PLC

	Bit 15	14	13	12	11	10	9	8	7	6	5	4	3	2	1	0
First ch of IN data	8	4	2	1	8	4	2	1	8	4	2	1	8	4	2	1
	Weight value (10^3)				Weight value (10^2)				Weight value (10^1)				Weight value (10^0)			

	Bit 15	14	13	12	11	10	9	8	7	6	5	4	3	2	1	0
Second ch of IN data					8	4	2	1	8	4	2	1	8	4	2	1
					Weight value (10^6)				Weight value (10^5)				Weight value (10^4)			

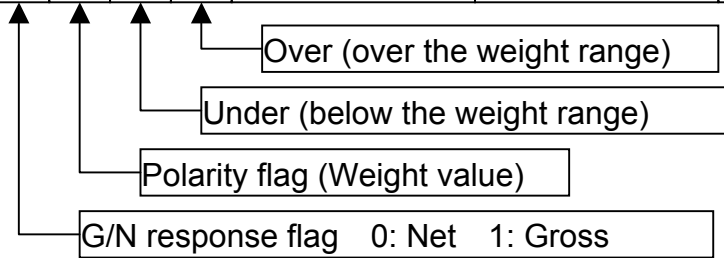

	Bit 15	14	13	12	11	10	9	8	7	6	5	4	3	2	1	0
Third ch of IN data									8	4	2	1	8	4	2	1
					Internally reserved				Unit				Decimal point position			

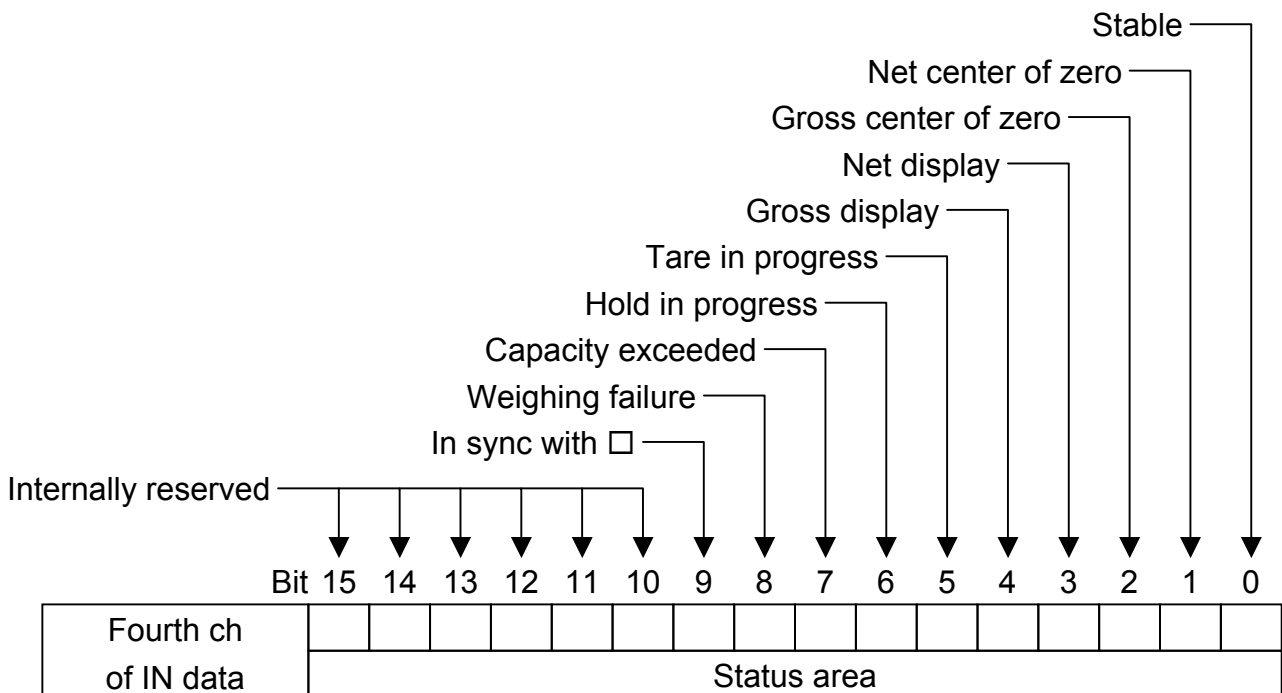
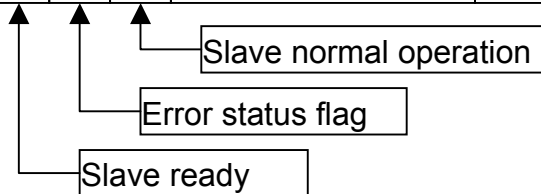

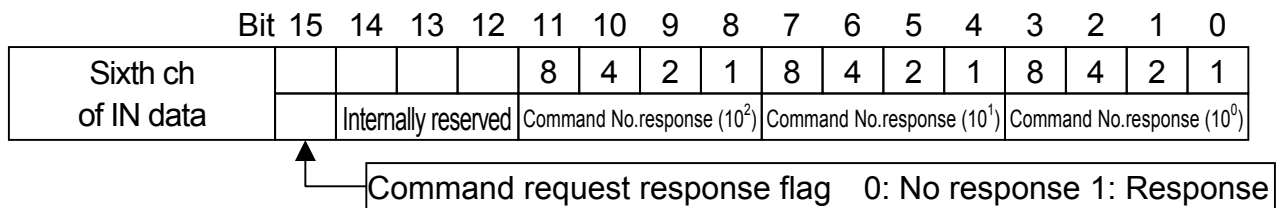
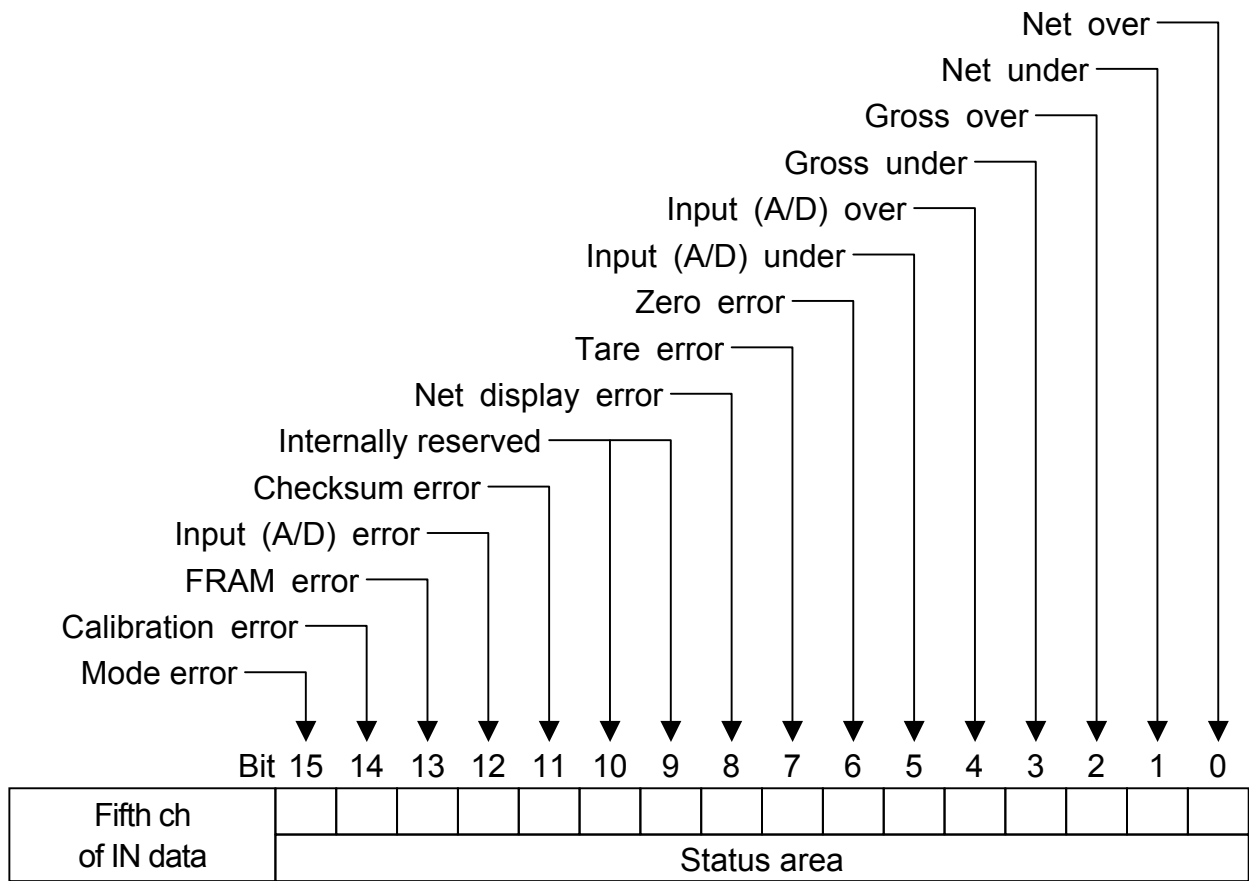

About IN Data

Slave ready -----Bit to turn ON when the AD-4408A is in the weighing mode.

Command No. response ---Response data to a command number.

Internally reserved -----Not used.

Status area -----The weighing status of the AD-4408A is output.

5.2. Handling Bits Directly

5.2.1. Handling Command Bits

- A command bit is in the first ch of OUT data.
- To execute, turn the corresponding command bit ON.
- The command bit will be effective at the rising edge.
The signal level must be maintained for 30 msec minimum.

Table 5 Command bits

	Command bit and action	
First ch of OUT data	Bit 0	Zero
	Bit 1	Clear the zero value
	Bit 2	Tare
	Bit 3	Clear the tare value
	Bit 4	Hold
	Bit 5	Net display
	Bit 6	Gross display
	Bit 7	Manual print command

5.2.2. Command Bit Execution Procedure

- Step 1 Turn OFF all the PLC memory command bits.
- Step 2 Turn ON the PLC memory command bit to be executed.
- Step 3 The AD-4408A executes the command.
- Step 4 Turn OFF all the PLC memory command bits.

5.3. Operation by Commands

5.3.1. Handling Commands

- Specify a command to execute to the command No.
- The command will be effective at the rising edge of the command request flag. The signal level must be maintained for 30 msec minimum.
- The response result to the command request is output as the command request response flag.
- The command response result is output as the command No. response.

5.3.2. Command Execution Procedure

Before execution

- Step 1 Confirm that the command request flag is turned OFF.
- Step 2 Specify the command to execute to the command No.

Execution

- Step 3 Confirm that the slave ready bit is turned ON.
- Step 4 Turn the command request flag ON. The command will be executed at the rising edge.
- Step 5 The AD-4408A responds. The response results are output as the command request response flag and command No. response.

After execution

- Step 6 Turn the command request flag OFF.

5.4. Commands

The master device uses the write command to convey instructions to the AD-4408A. For details, refer to “7.1. Write Command” of “7. Timing Chart”.

Table 6 Commands

Command No.	Command
1	Zero
2	Clear the zero value
3	Tare
4	Clear the tare value
5	Hold
6	Net display
7	Gross display
8	Manual print command



6. Errors

6.1. Error Types

Error Status Flag

This conveys to the master device that an error has occurred.

Turn the error reset flag ON to request resetting the error status flag.

Table 7 Error status flag

Error type	Causes
Checksum error	Program checksum does not match.
Input (A/D) error	Data can not be acquired from the A/D converter.
FRAM error	Data can not be written into the FRAM.
Calibration error	Calibration data is not correct.
Mode error	Moved to a mode other than the weighing mode.

Weighing Failure

This conveys a weighing failure to the master device.

This will be reset when normal weighing has resumed.

Table 8 Weighing failure

Error type	Causes
Zero error	Zero adjustment is not performed.
Tare error	Tare is not performed.
Net display error	A net value is not displayed.
Capacity exceeded	The weighing capacity has been exceeded.

Capacity Exceeded

This conveys to the master device that the weighing capacity has been exceeded.

This will be reset when all the errors are cleared.

Table 9 Capacity exceeded

Error type	Causes
Net over	The net weight is over the net weight range.
Net under	The net weight is below the net weight range.
Gross over	The gross weight is over the gross weight range.
Gross under	The gross weight is below the gross weight range.
A/D over	A/D value is over the A/D value range.
A/D under	A/D value is below the A/D value range.



7. Timing Chart

7.1. Write Command

Write Command

Specify the command to execute to the command No. .

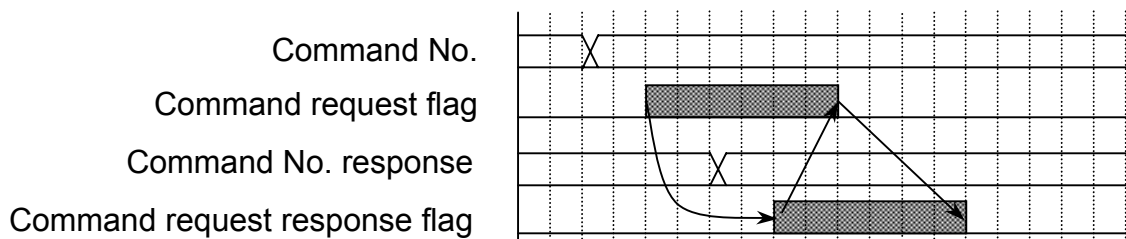

Fig.5 Write command

Slave Normal Operation

Slave normal operation is a signal to confirm that the AD-4408A is connected to the power and is in normal operating conditions. During normal operation, the signal is reversed at a 0.5 to 1 second interval.

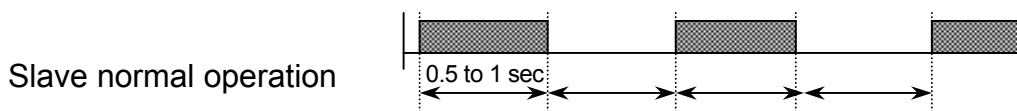

Fig.6 Slave normal operation signal

Error status flag

If an AD-4408A error has occurred, the slave ready bit will be turned OFF and the error status flag will be turned ON to convey to the master device that an error has occurred. The master device will turn the error reset flag ON to request resetting the error status flag.

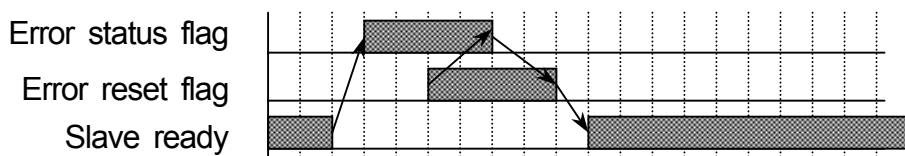

Fig.7 Resetting the error status flag

Table 10 Command bits / Status bits

Memory		Description
First ch of OUT data	Bit 14	Error reset flag
Third ch of IN data	Bit 13	Slave normal operation
	Bit 14	Error status flag
	Bit 15	Slave ready



8. Check Mode

8.1. Checking the DeviceNet Communication Status

8.1.1. Entering the Check Mode

Step 1 While pressing and holding the ENTER key, press the F key.

`[FnC]` is displayed to indicate that the indicator will enter the general function mode.

To go back to the weighing mode, press the ESC key.

Step 2 While pressing and holding the ZERO key, press the ENTER key.

`[hc]` is displayed to indicate that the indicator will enter the check mode.

Press the ENTER key again to display an item to be checked.

Step 3 Press the or key to select `[hc dn]` (DeviceNet check mode) and press the ENTER key to enter the DeviceNet check mode.

To exit from the check mode, press the ESC key.

Table 11 Check mode list

Display	Checking item
<code>[hcPEY]</code>	Key switches
<code>[hc [L]</code>	Standard serial output
<code>[hc***</code> <code>[hc dn</code> <code>[hc***</code>	Interfaces DeviceNet
<code>[hc rS]</code>	Testing terminal
<code>[hc Ad]</code>	A/D (Load cell)
<code>[hc in]</code>	Internal count
<code>[hcPr9]</code>	Program version
<code>[hc Sn]</code>	Serial number
<code>[S Pr9]</code>	Program checksum
<code>[S FrA]</code>	Memory (FRAM) checksum
<code>[ALFdE]</code>	Calibration-related functions

8.1.2. Checking the Communication Status

Press the or key to change addresses.

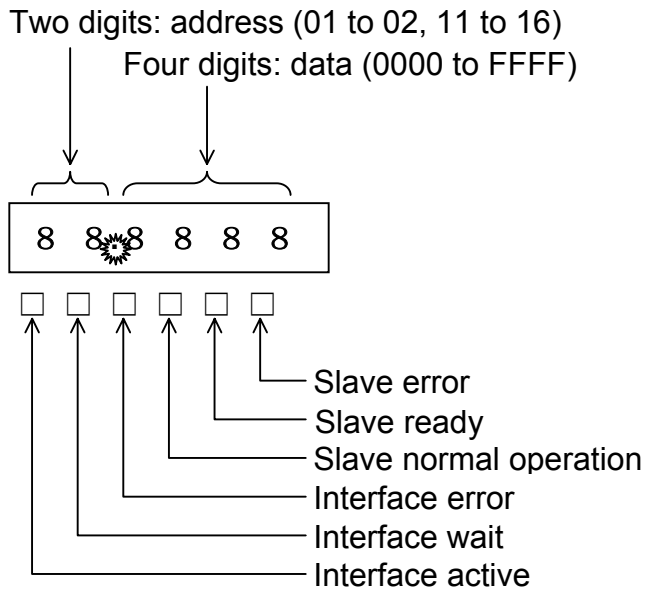

Address	Data type	Ch
01 to 02	OUT data	1 to 2
11 to 16	IN data	1 to 6



A&D Company, Limited

3-23-14 Higashi-Ikebukuro, Toshima-ku, Tokyo 170-0013 JAPAN
Telephone: [81] (3) 5391-6132 Fax: [81] (3) 5391-6148

A&D ENGINEERING, INC.

1756 Automation Parkway, San Jose, California 95131 U.S.A.
Telephone: [1] (408) 263-5333 Fax: [1] (408)263-0119

A&D INSTRUMENTS LIMITED <UK Office>

Unit 24/26 Blacklands Way, Abingdon Business Park, Abingdon, Oxfordshire
OX14 1DY United Kingdom
Telephone: [44] (1235) 550420 Fax: [44] (1235) 550485

A&D INSTRUMENTS LIMITED <German Sales Office>

Große Straße 13 b 22926 Ahrensburg Deutschland
Telefon: [49] (0) 4102 459230 Telefax: [49] (0) 4102 459231

A&D Australasia Pty Ltd.

32 Dew Street, Thebarton, South Australia 5031 AUSTRALIA
Telephone: [61] (8) 8301-8100 Fax: [61] (8) 8352-7409

A&D KOREA Limited

한국에이.엔.디(주)
대한민국 서울시 영등포구 여의도동 36-2 맨하탄 빌딩 8층
(8th Floor, Manhattan Bldg. 36-2 Yoido-dong, Youngdeungpo-ku, Seoul, KOREA)
전화: [82] (2) 780-4101 팩스: [82] (2) 782-4280

A&D RUS CO., LTD.

Компания Эй энд Ди Рус
121357, Российская Федерация, г.Москва, ул. Верейская, дом 17
(Bldg. 17, Vereyskaya st., Moscow, 121357 RUSSIAN FEDERATION)
тел.: [7] (495) 937-33-44 факс: [7] (495) 937-55-66

A&D Instruments India Private Limited

ऐ&डी इन्स्ट्रूमेन्ट्स इण्डिया प्रा० लिमिटेड
509, उद्योग विहार , फेस -5, गुडगांव - 122016, हरियाणा , भारत
(509, Udyog Vihar, Phase-V, Gurgaon - 122 016, Haryana, India)
फोन : 91-124-4715555 फैक्स : 91-124-4715599